

SEDAR

— Since 1892 —

RB 16-53 Roller Blind Motor Rail System - Somfy Altus® 40

Technical Document



About this Document

This document is a detailed technical resource for **the RB 16-53 Roller Blind Motor Rail System - Somfy Altus® 40**, offering in-depth specifications to aid engineers, installers, and architects in understanding the product's technical intricacies.

To access additional system documents, please click on the links provided below or scan the accompanying QR code for immediate redirection to the relevant document.



[16-53 Documents](#)



[Roller Blinds Fabric Specifications](#)

For inquiries about **the RB 16-53 Roller Blind Motor Rail System - Somfy Altus® 40** or to utilize our Projects Department's bespoke services, please contact us using the QR code below for guidance in transforming your spaces with innovation and style. Our team is ready to assist with product details, installation, and custom solutions, ensuring your design needs are expertly met.



Email: projects@sedarglobal.com

Projects Hotline: [+971502313453](tel:+971502313453)

Table Of Contents

About this Document	02
System Description	04
System Limitations	04
System Drawing	05
System Profile Drawings	06
Measurement Diagram	09
Measurement Instructions	10
Fitting Techniques	13
Installation Instructions	14
Operation/Control	17
Side Channel Options	18
Valance	20
Standard Valance	20
Double Bracket	21
Motorization	22
General Safety Instructions	23
Other Relevant Documents	24
Projects and Professionals Contact Information	24

System Description

The **Sedar RB 16-53 Roller Blind Motor Rail System - Somfy Altus® 40** is a versatile solution which features a 50 mm pipe that is suitable for residential, commercial, and larger spaces. This system is remote controlled, and automation compatible powered by Somfy Altus® 40 that allows for wireless radio control of motorized window covering.

This system has a vast selection of fabric choices, offering custom-printed blinds for a personal touch. It is easy to install and compatible with substrates such as concrete, wood, reinforced gypsum, and metal.

This product comes with the following warranties:

Products	Warranties
Sunscreen Fabric	10 years
Blackout Fabric	1 year
Non-Blackout Fabric	1 year
Motor and System	10 years

System Limitations

Description	Value
Tube	50 mm
Minimum Width	67 cm
Maximum Width	260 cm
Minimum Height	20 cm
Maximum Height	550 cm

Note: Larger dimensions are allowed through Ultrasonic Welding.

System Drawing

System: 16-53 Roller Blind Motor Rail System - Somfy Altus® 40

Operation: Remote Controlled and Automation Compatible*

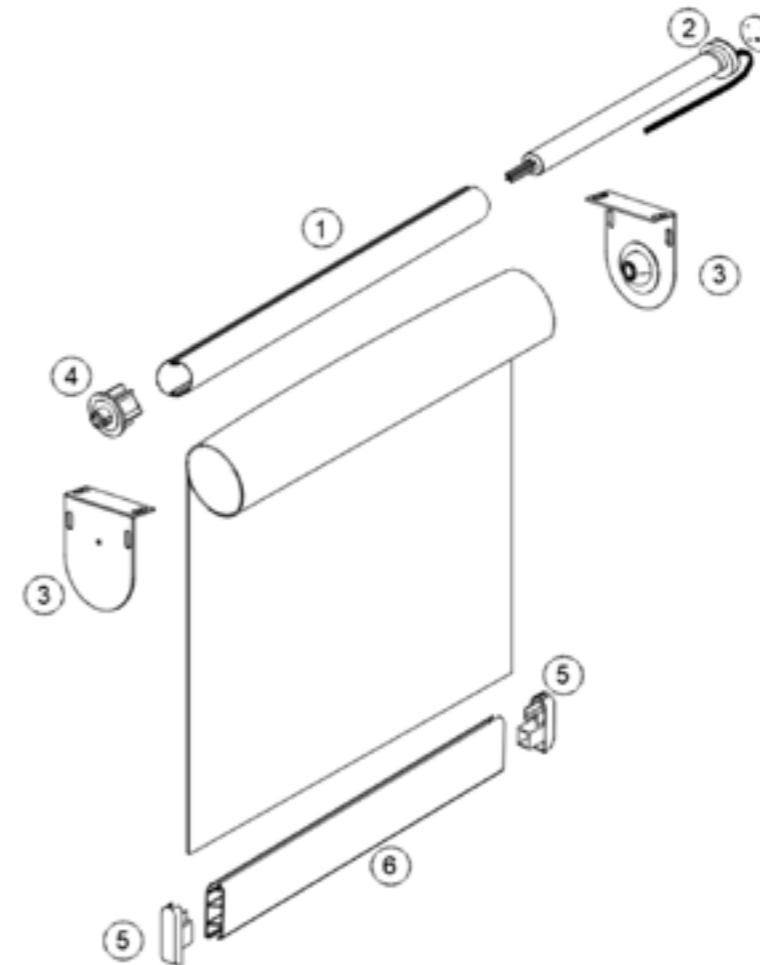

Part No.	Description
1	Roller Blinds Top Tube - Aluminum
2	Somfy Altus® 40
3	Bracket for RB 16-53 System
4	End Plug
5	Bottom Rail End Cap
6	Powder Coated Bottom Rail

***Note:** Contact your system integrator for automation system.

Profile Drawings

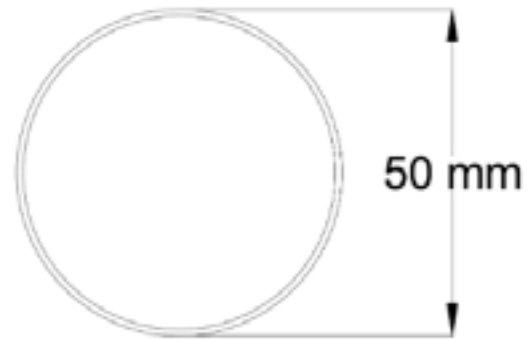

Tube size (50 mm)
 Material: Aluminum
 Aluminum Grade: 6063 - T6
 Thickness: 1.5 mm



Perspective

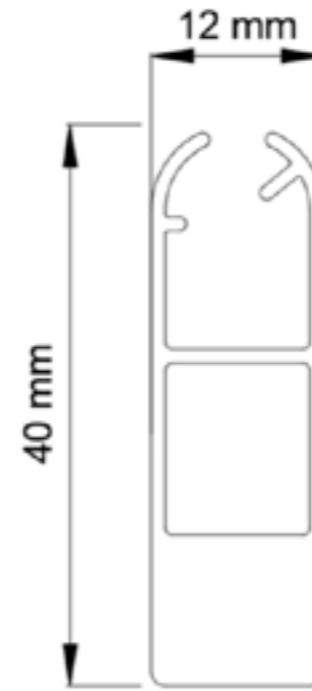

Heavy Bottom Rail (For Request)
 Material: Aluminum
 Aluminum Grade: 6063 - T6

Color		
Cream	Gray	White
●	●	○

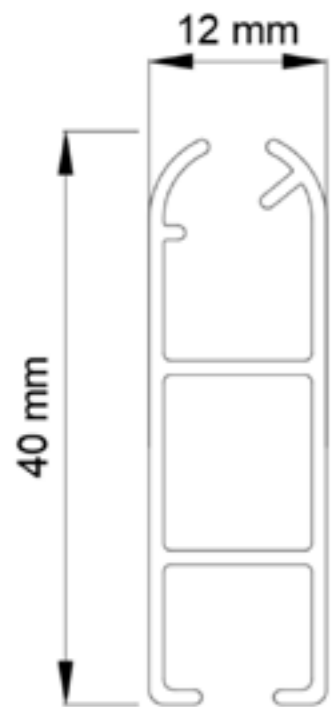

Light Bottom Rail (Standard)
 Material: Aluminum
 Aluminum Grade: 6063 - T6

Color		
Cream	Gray	White
●	●	○

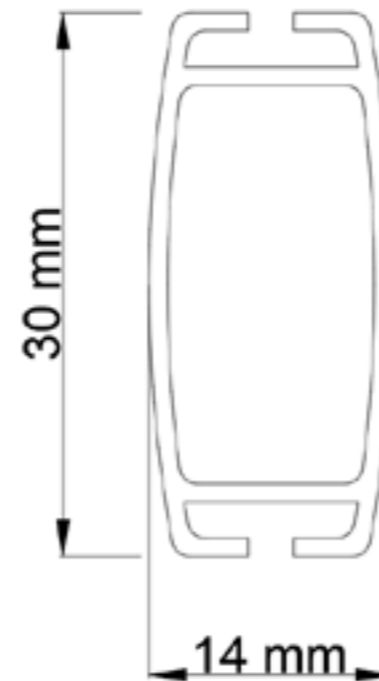

Covered Bottom Rail (For Request)
 Material: Aluminum
 Aluminum Grade: 6063 - T6

Note: This bottom rail is wrapped with the same fabric material as the blind.

Color		
Cream	Gray	White
●	●	○

Measurement Diagram

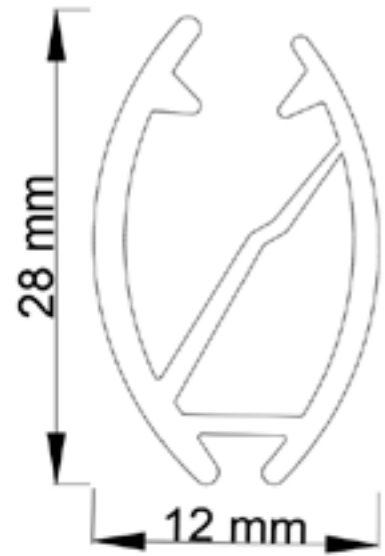

Elite Bottom Rail (For Request)

Material: Aluminum

Aluminum Grade: 6063 - T6

Color		
Silver ●	Gold Brushed ●	Black ●
Rose Brushed ●	Copper Brushed ●	



Elite Bottom Rail with their Colors (For Request)

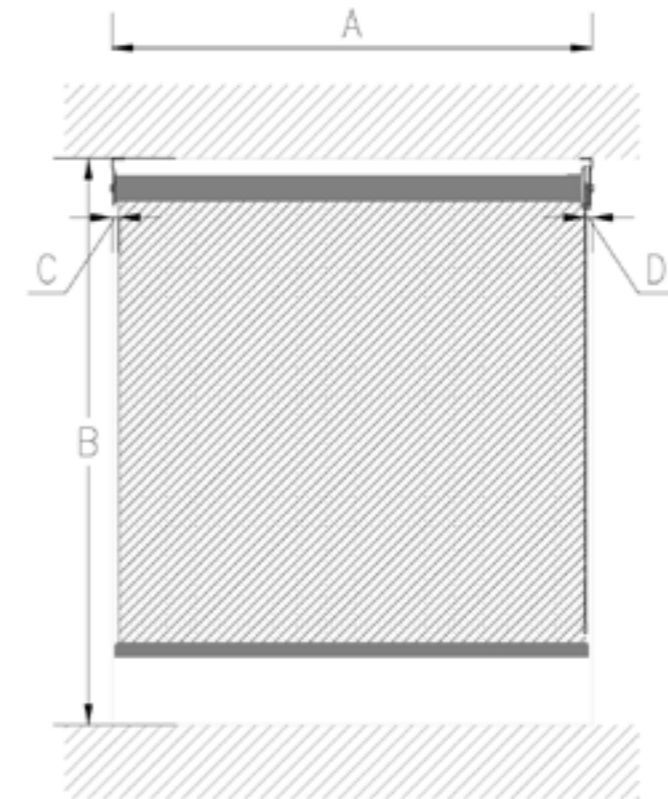

A- System width. If the roller is mounted inside the window frame, reduce the width by 1 cm. For outdoor mounting, we recommend adding 10 cm on each side.

B- System height

C- Light gap on left side 25 mm

D- Light gap on right side 25 mm

Measurement Instructions

Tools Needed



1. Measuring tape (metal)



2. Pencil and notepad



3. Step ladder

Inside Mount Roller Blinds Measurement Instructions

Step 1:

Measure the top, middle, and bottom then record the narrowest.

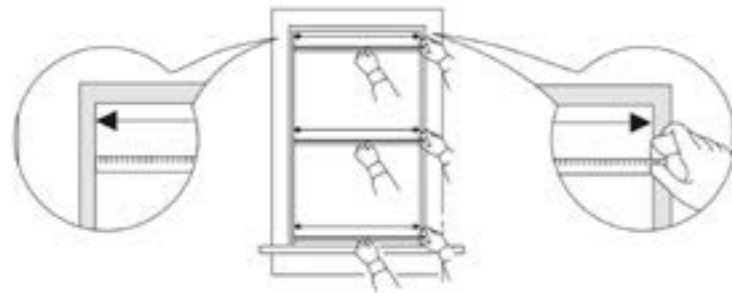

Step 2:

Measure the left center and right then record the longest height.

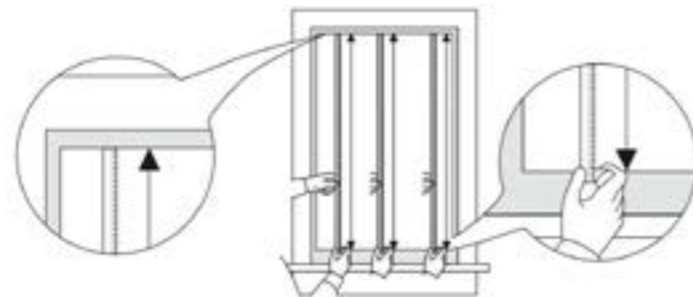

Step 3:

Measure and record the depth of the window.



Note: The minimum depth required (without valance) is 8.5 cm for a flush look.

Things to consider

Considerations for Valance (Optional):

- Valance measurement should equal the window width.
- Expect gaps (2.5 cm) on the sides.
- Pay attention to door knobs and handles. If they are present, think about opting for an outside mount.
- Note that with the cassette, the blind cannot roll outwards, only inside rolling is possible.
- Minimum depth required for valance is 10 cm.

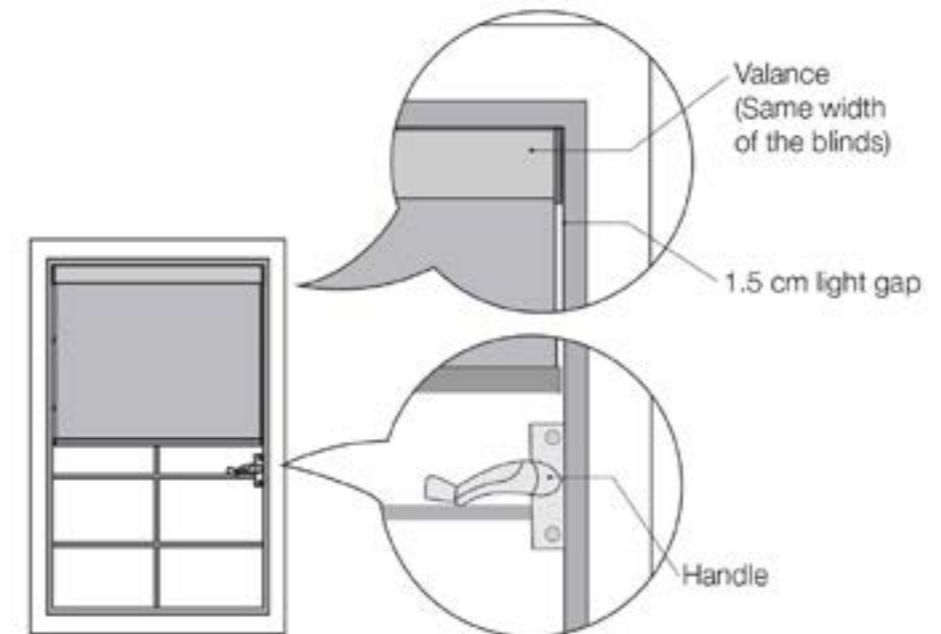

Outside Mount Roller Blinds Measurement Instructions

Step 1:

Measure the middle width of the window.

Step 2:

Add 7.5 cm - 15 cm to each side to minimize light penetration.

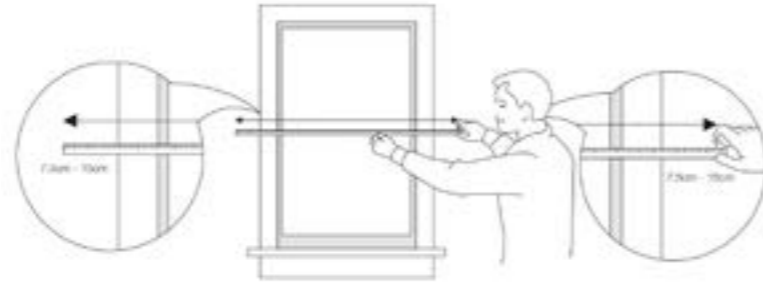

Step 3:

Measure the height from the middle of the window. The height will depend on your measurement.

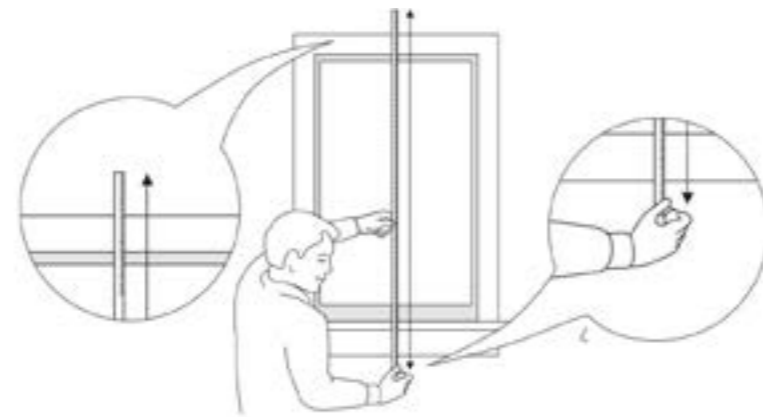

Considerations for Valance:

- Cornice and valance measurements will be automatically manufactured 1.5 cm wider than the blinds.
- Maintain a minimum of 15 cm above the window for installation.

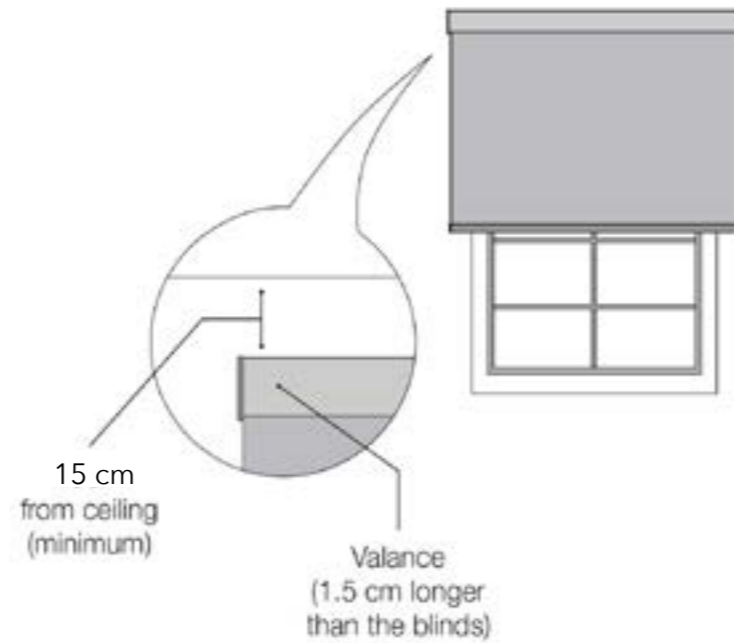

Fitting Techniques

Note: 80 mm clear surface area is required for installation and a drop of 95 mm.

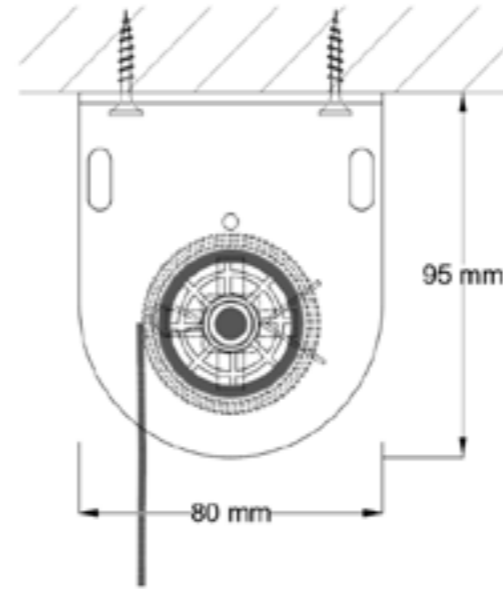

Ceiling Mount

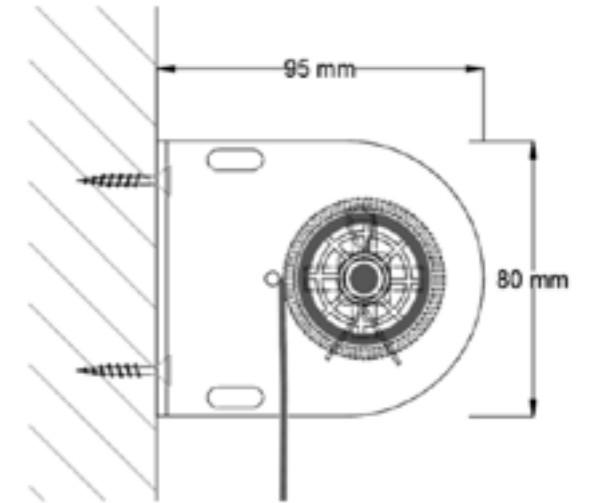

Wall Mount

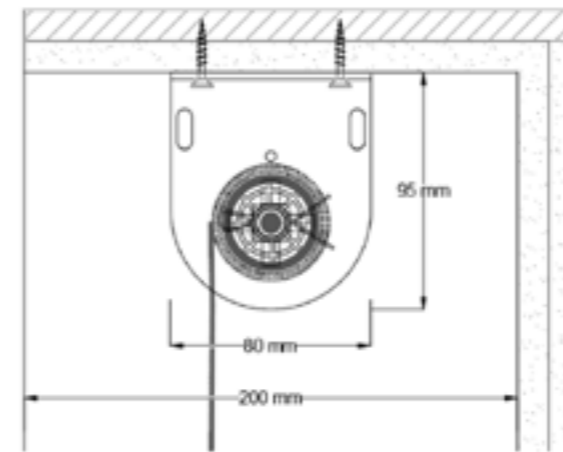

Recess Mount

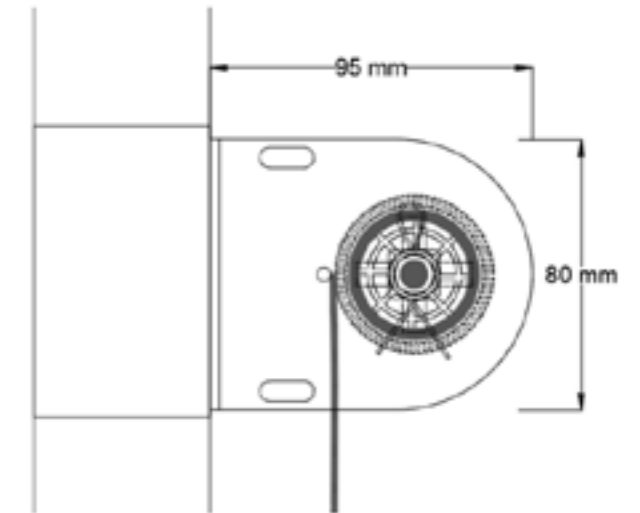

Glue Mount

Installation Instructions

Tools needed



- 1. Measuring tape (metal)
- 2. Pencil (for marking)
- 3. Work gloves
- 4. Drill Machine
- 5. Drill Bit
- 6. Screws
- 7. Wall Plug (Wall Anchor)

The requirement for each type of installation to provide strength and corrosion resistance in various types of installation surface applications:

- 1. Aluminum - Stainless steel self-drilling screws.
- 2. Concrete - 6 mm screws and plugs are required for installation.
- 3. Gypsum - Special butterfly screws and plugs are required for installation.

Installation Steps:

Step 1:
Measure the wall, ceiling, and window.



Step 2:
Mark the position of the first bracket.

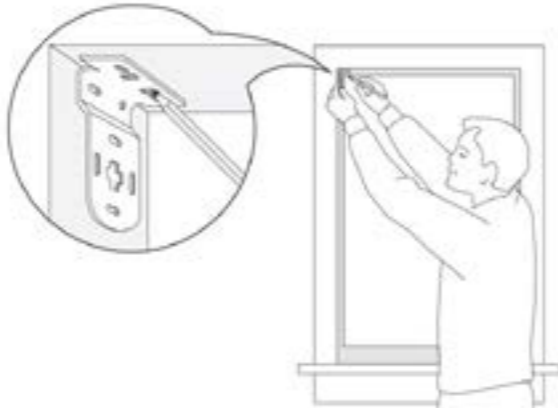

Step 3:
Fix the first bracket using a drill or screwdriver.

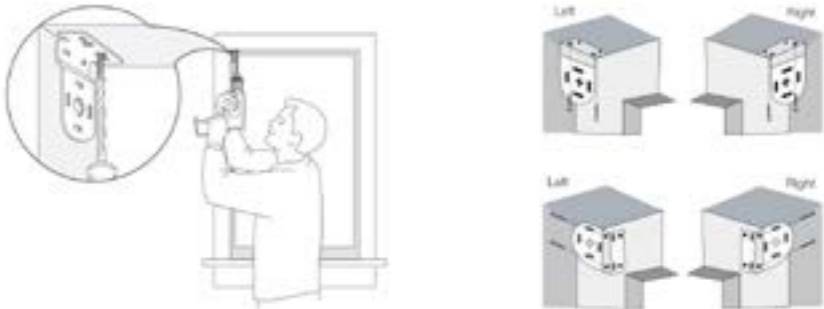

Step 4:
Measure and mark the position of the second bracket, ensuring it aligns with the first.



Step 5:
Install the second bracket using a drill.

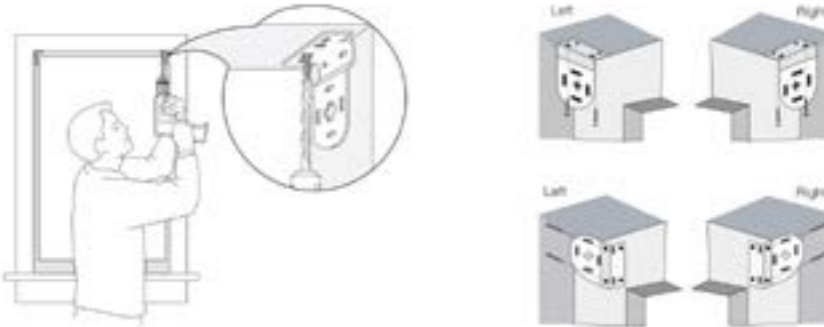

Step 6:
Attach the bracket cover on both sides.

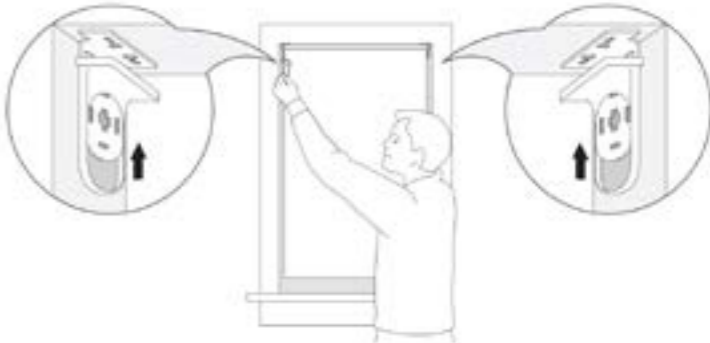

Step 7:

Insert the roller blind on one side.

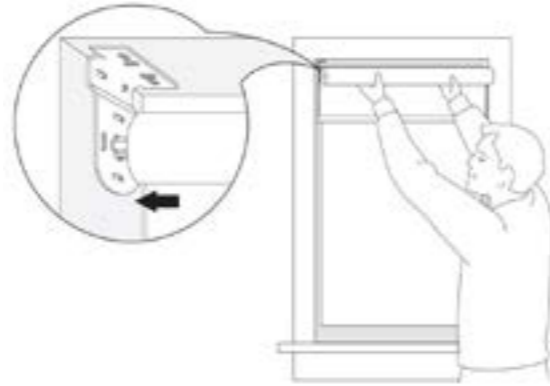

Step 8:

Insert the other end by pushing the spring inwards into the bracket.

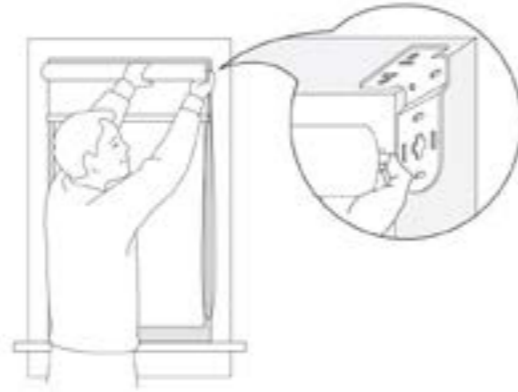

Step 9:

Test if the roller shades is installed properly. Do not exert too much pressure.



Step 10:

Check if it's working correctly using the Somfy remote control.

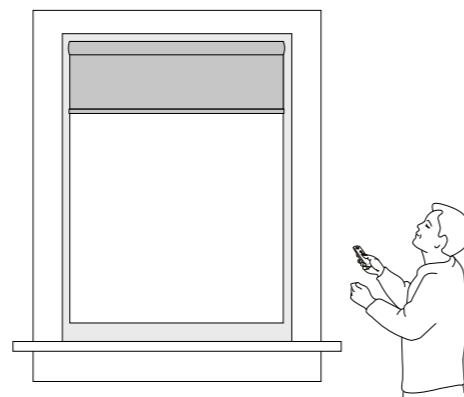

Tip

- Alignment of brackets should be exact to avoid damaging the product.

Operation/Control

Raising or Lowering:

- Step 1: Press the 'down' button on your Somfy remote control to close the blind.
- Step 2: Press the 'up' button on your Somfy remote control to open the blind.

You can press the "My" buttons on your Somfy remote

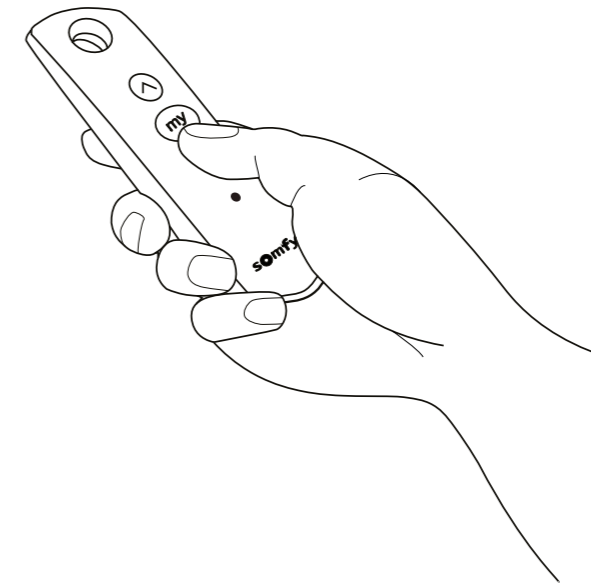

Product Maintenance and Cleaning

- Regularly dust with a feather duster or soft cloth.
- For thorough dust removal, use a hand-held vacuum with low suction.
- CAUTION: Avoid harsh detergents.

Side Channel Option

A side channel is a vertical guide installed on either side of a window to slot the edges of the blind fabric, enhancing functionality and aesthetics.

The set includes an aluminum cassette, side channel profiles, and a bottom bar in standard white, cream, or beige finishes.





The fabric edges are secured with a dual brush insert, and operation is through a stainless steel ball chain.

Single Side Channel

Material: Aluminum

Aluminum Grade: 6063 - T6

Thickness: 1.5 mm

Color	
Cream 	Gray 
White 	Mill Finish 

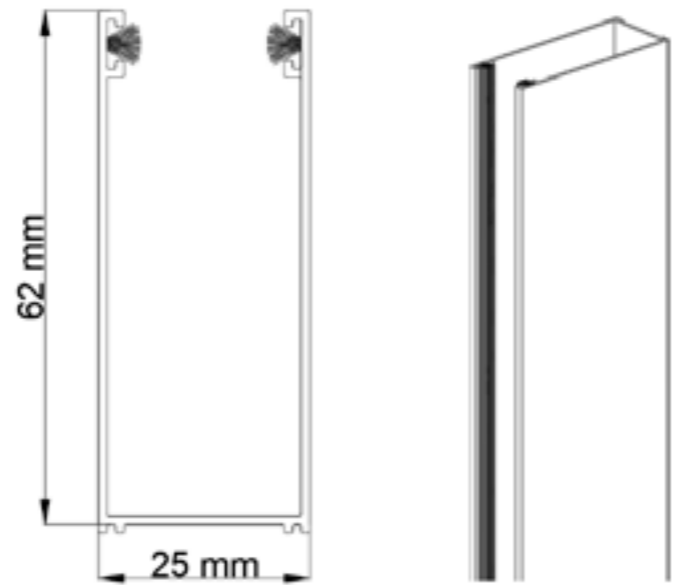

Profile

Perspective

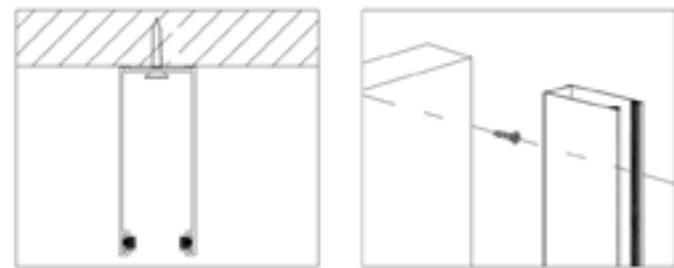

Screw mounting technique

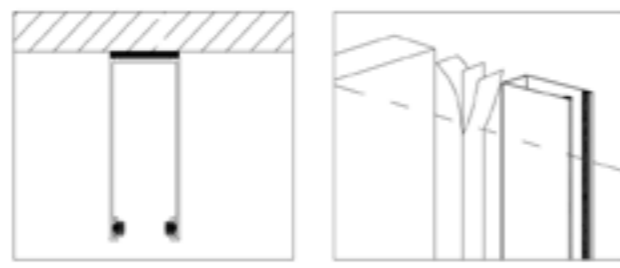



Double-sided tape mounting technique

Double Side Channel

Material: Aluminum

Aluminum Grade: 6063 - T6

Thickness: 1.5 mm

Color		
Mill Finish 	Gray 	White 

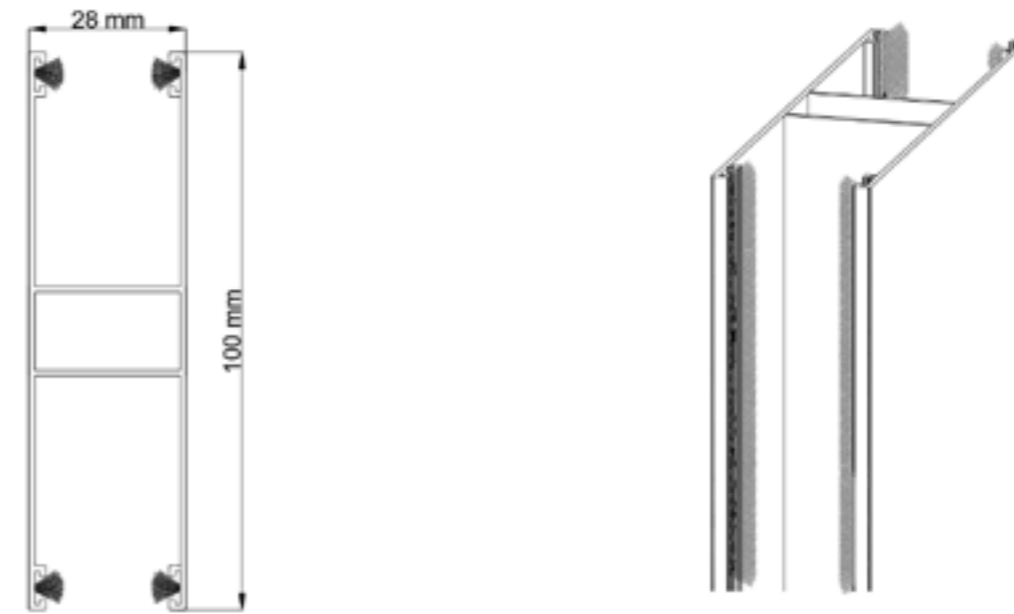

Secure two or more sequential roller blinds on aluminum surfaces for light-blocking purposes and enhanced aesthetics, utilizing either double-sided tape or adhesive.

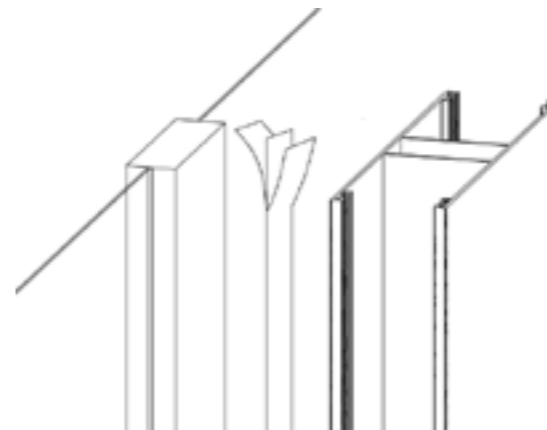

Installing on aluminum using double sided tape

Valance

A valance improves roller blinds by concealing the top pipe and hardware. It shields the mechanism from dust and damage, reducing maintenance and extending system life.

Standard Valance

System Code: 16-71

Material: Aluminum

Aluminum Grade: 6063 - T6



Profile

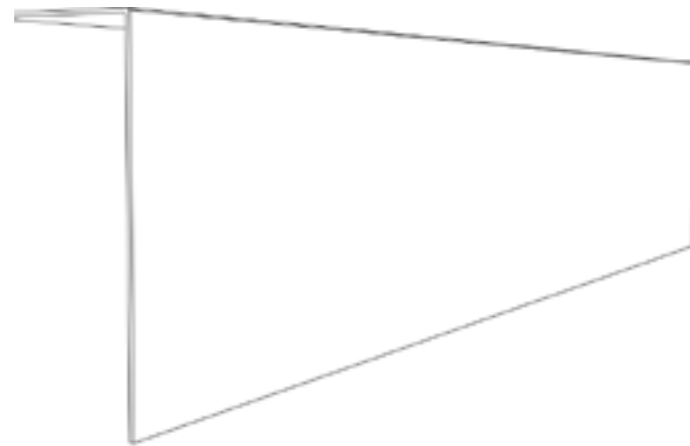

Perspective

Standard Valance Fitting Diagram

1. Measure and mark valance location on ceiling.
2. Drill holes, insert anchors.
3. Place valance and ensure it's centered and level.
4. Double-check alignment, adjust if needed.
5. Wipe away marks and dust.

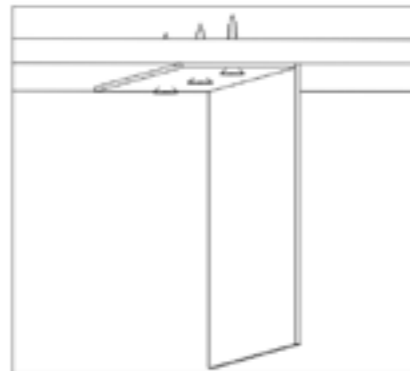
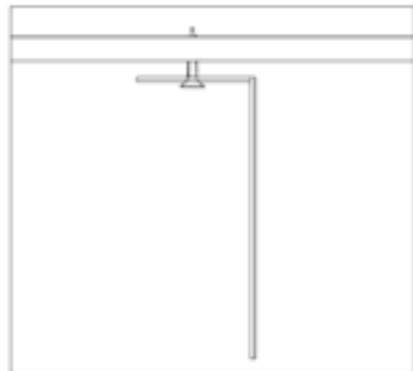

Double Bracket

The **RB 16-53 Roller Blind Motor Rail System - Somfy Altus® 40** doesn't have the double bracket feature. Use the QR code or the link below to see our product options that offer the double bracket feature.



[RB 16-11 Roller Blind Manual System 40](#)



[RB 16-12 Roller Blind Manual System 45](#)

Motorization

The **RB 16-53 Roller Blind Motor Rail System - Somfy Altus® 40** is powered by Somfy Altus® 40 RTS.

The Somfy Altus® 40 RTS is a motor designed for interior window coverings, known for its quiet operation and ease of use. The system supports Radio Technology Somfy (RTS), an exclusive remote control protocol used to operate and control wirelessly.

Technical Data

Thermal Type	4 minutes	Temperature Working Range	-10°C to +40°C
Supply	AC	Electric Insulation	Class II
Index Protection Rating	IP 44 (Indoor Use Only)	Capacity of Memory	12 different transmitters plus 3 wireless sensors
Limit Switch Unit	Electronic	Coding	Rolling code with 16 million possibilities
Limit Switch Capacity	Unlimited		

Dimensions

	3/30	13/10
L (mm)	497	497

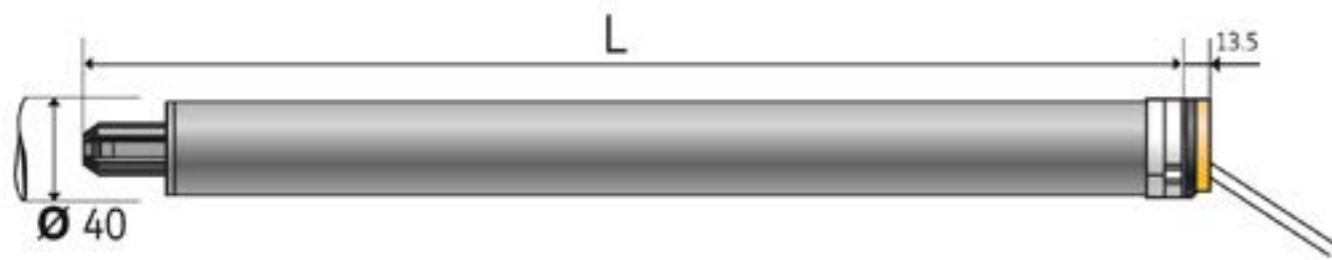

Performances

Nominal Voltage	230 V / 50 Hz	
Torque (Nm)	3	13
Speed (rpm)	30	10
Rated Current (A)	0.42	0.52

For more information, you can visit: <https://www.somfy.com/en-en/>

General Safety Instructions

Ensure adults adhere to these safety guidelines provided by Sedar:

- If the blind is not raised or lowered evenly, it can become damaged.
- If the fabric is not level as it rolls, it may wrap around the tube incorrectly, leading to wrinkles and could tear over time.
- Never immerse the motor in liquid.
- Never drill holes in the motor.
- Do not drop the motor and avoid impacts.
- Follow safety standards during product installation and maintenance.

Other Relevant Documents

To further explore **the RB 16-53 Roller Blind Motor Rail System - Somfy Altus® 40**, please click the links below or scan the QR codes. These will direct you to our System Brochure and Technical Summary, offering in-depth information and visual guides to assist in your project planning.



[16-53 Documents](#)



[Roller Blinds Fabric Specifications](#)

Projects and Professionals Contact Information

For inquiries about **the RB 16-53 Roller Blind Motor Rail System - Somfy Altus® 40** or to utilize our Projects Department's bespoke services, please contact us. Our team is ready to assist with product details, installation, and custom solutions, ensuring your design needs are expertly met. Contact us using the QR code below for guidance in transforming your spaces with innovation and style.



Email: projects@sedarglobal.com

Projects Hotline: [+971502313453](tel:+971502313453)